

51210ASY

---

**EQUIPTO**

---

Open Work Bench Assembly  
Instructions

**READ INSTRUCTIONS BEFORE ASSEMBLING**

# OPEN – LEG BENCH ASSEMBLY INSTRUCTIONS

## TABLE OF CONTENTS

1. BACK STRINGER ASSEMBLY. . . . .	PAGE 2
2. BOTTOM SHELF ASSEMBLY. . . . .	PAGE 3
3. STEEL TOP ASSEMBLY. . . . .	PAGE 4
4. FILLER INSTALLATION. . . . .	PAGE 5
5. WOOD TOP ASSEMBLY. . . . .	PAGE 6
6. CONTINUOUS BENCH ASSEMBLY. . . . .	PAGE 7
7. MOBILE CASTER KIT. . . . .	PAGE 7

# Step

1

## BACK STRINGER ASSEMBLY

### BENCH LEGS

NO.	DEPTH	HEIGHT
#9921	28 1/2"	29"
#9922	28 1/2"	31 1/4"
#9923	28 1/2"	34"
#9931	34 1/2"	29"
#9932	34 1/2"	31 1/4"
#9933	34 1/2"	34"

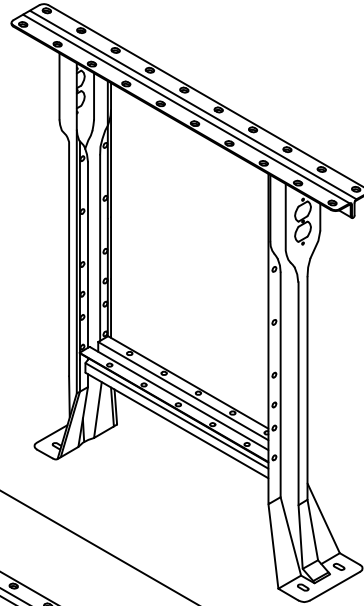

### NOTE

DO NOT TIGHTEN THE BOLTS UNTIL THE WORKBENCH IS COMPLETELY ASSEMBLED.

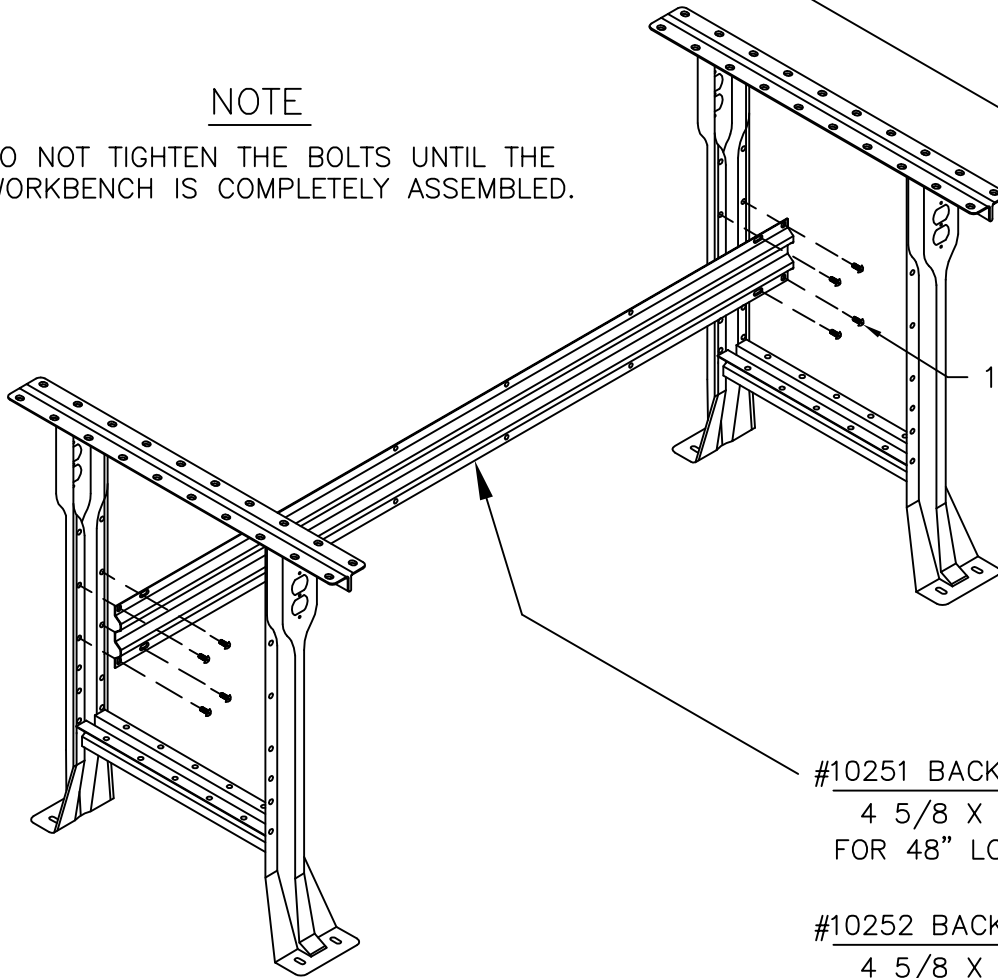

13154 TRUSS HD MACH SCREW

#10251 BACK STRINGER  
4 5/8 X 46 3/4"  
FOR 48" LONG BENCH

#10252 BACK STRINGER  
4 5/8 X 58 3/4"  
FOR 60" LONG BENCH

#10253 BACK STRINGER  
4 5/8 X 70 3/4"  
FOR 72" AND 96" LONG BENCH

#13154 TRUSS HD MACH SCREW  
5/16" X 3/4"

#13051 TWIN WHIZZ LOCKNUT  
5/16" - 18

(8 PER STRINGER)

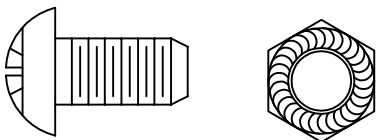

FULL SCALE

## 2

# BOTTOM SHELF ASSEMBLY

### NOTE

ALL BENCHES DO NOT REQUIRE  
A BOTTOM SHELF.

### NOTE

DO NOT TIGHTEN THE BOLTS UNTIL THE  
WORKBENCH IS COMPLETELY ASSEMBLED.

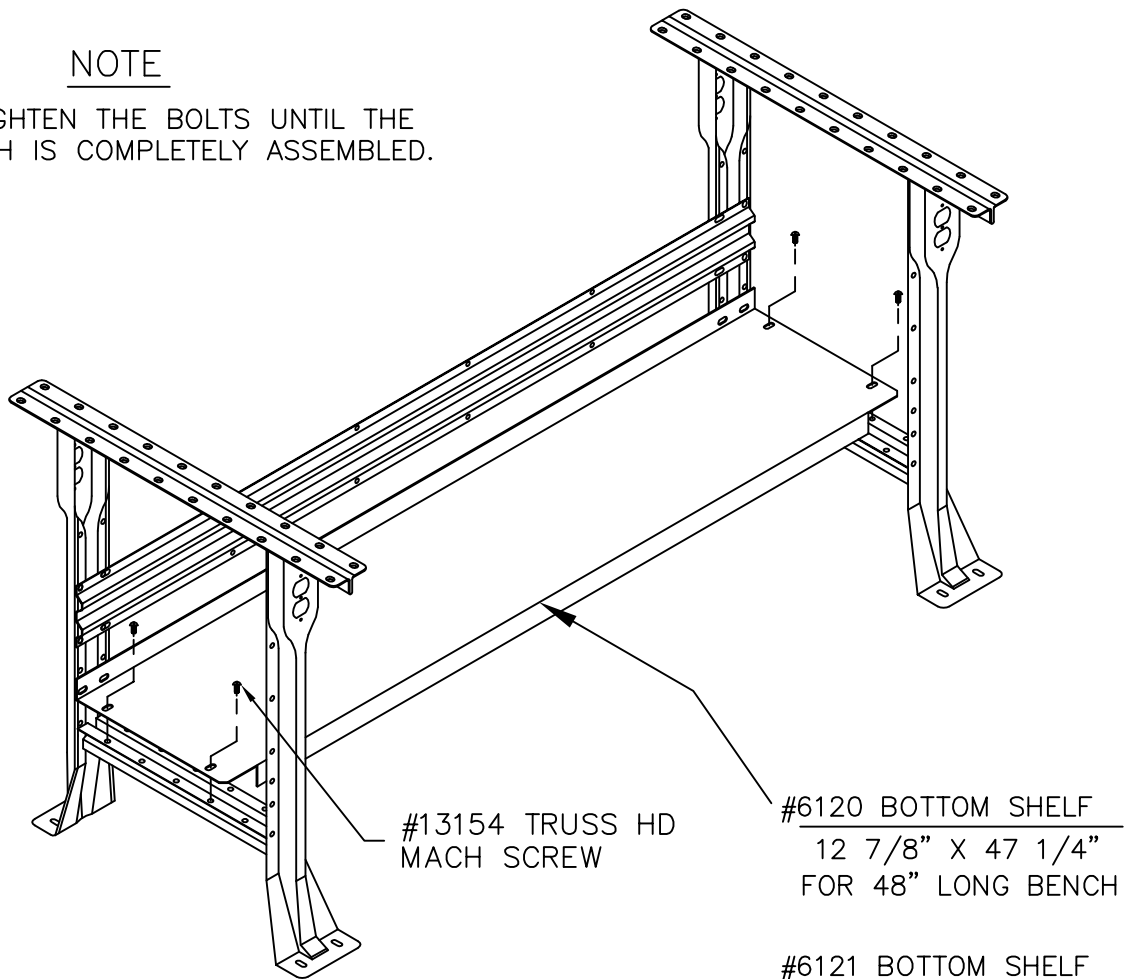

#13154 TRUSS HD  
MACH SCREW

#6120 BOTTOM SHELF  
12 7/8" X 47 1/4"  
FOR 48" LONG BENCH

#6121 BOTTOM SHELF  
12 7/8" X 59 1/4"  
FOR 60" LONG BENCH

#6122 BOTTOM SHELF  
12 7/8" X 71 1/4"  
FOR 72" AND 96" LONG BENCH

#13154 TRUSS HD MACH SCREW  
5/16" X 3/4"

#13051 TWIN WHIZZ LOCKNUT  
5/16" - 18

(4 PER BOTTOM SHELF)

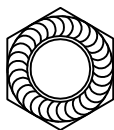
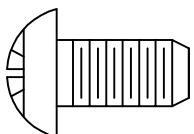

FULL SCALE

# Step

# 3

## STEEL TOP ASSEMBLY

**NOTE**

FOR HARDBOARD ON STEEL, AFTER TOP IS ATTACHED INSERT PLUGS AS SHOWN.

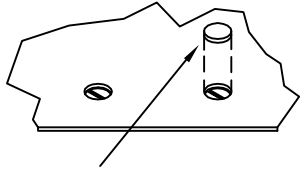

#10206-3/4" DIA. PLUG

**HARDBOARD ON STEEL (12 GA.)**

FLANGE DOWN	SIZE	FLANGE UP
#441D4M	30" x 48"	#441U4M
#441D5M	30" x 60"	#441U5M
#441D6M	30" x 72"	#441U6M
#441D8M	30" x 96"	#441U8M
#442D4M	36" x 48"	#442U4M
#442D5M	36" x 60"	#442U5M
#442D6M	36" x 72"	#442U6M
#442D8M	36" x 96"	#442U8M

**STEEL (12 GA.)**

FLANGE DOWN	SIZE	FLANGE UP
#11479D	30" x 48"	#11479
#11480D	30" x 60"	#11480
#11481D	30" x 72"	#11481
#11482D	30" x 96"	#11482
#11463D	36" x 48"	#11463
#11464D	36" x 60"	#11464
#11465D	36" x 72"	#11465
#11370D	36" x 96"	#11370

**NOTE**

OPTIONAL END RAILS AND AERIAL SHELF MUST BE ATTACHED AT THIS POINT. IF YOU HAVE AN AERIAL SHELF SEE THOSE INSTALLATION INSTRUCTIONS.

**END RAILS (16 GA.)**

LEFT HAND	SIZE	RIGHT HAND
#7417L	30" STEEL	#7417R
#7418L	36" STEEL	#7418R

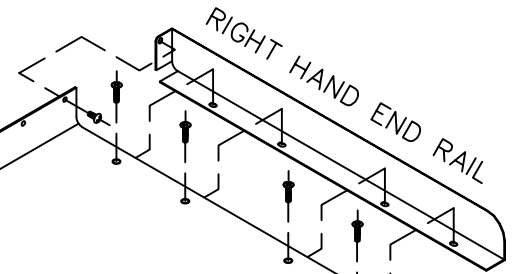

**NOTE**

STEEL TOPS MUST SLIDE ONTO LEG TOP BRACES.

FLANGE DOWN

FLANGE UP

STEEL TOP

#13165 TRUSS HD MACH SCREW

**NOTE**

THE NAME "EQUIPTO" IS TO BE TOWARD THE FRONT OF THE BENCH.

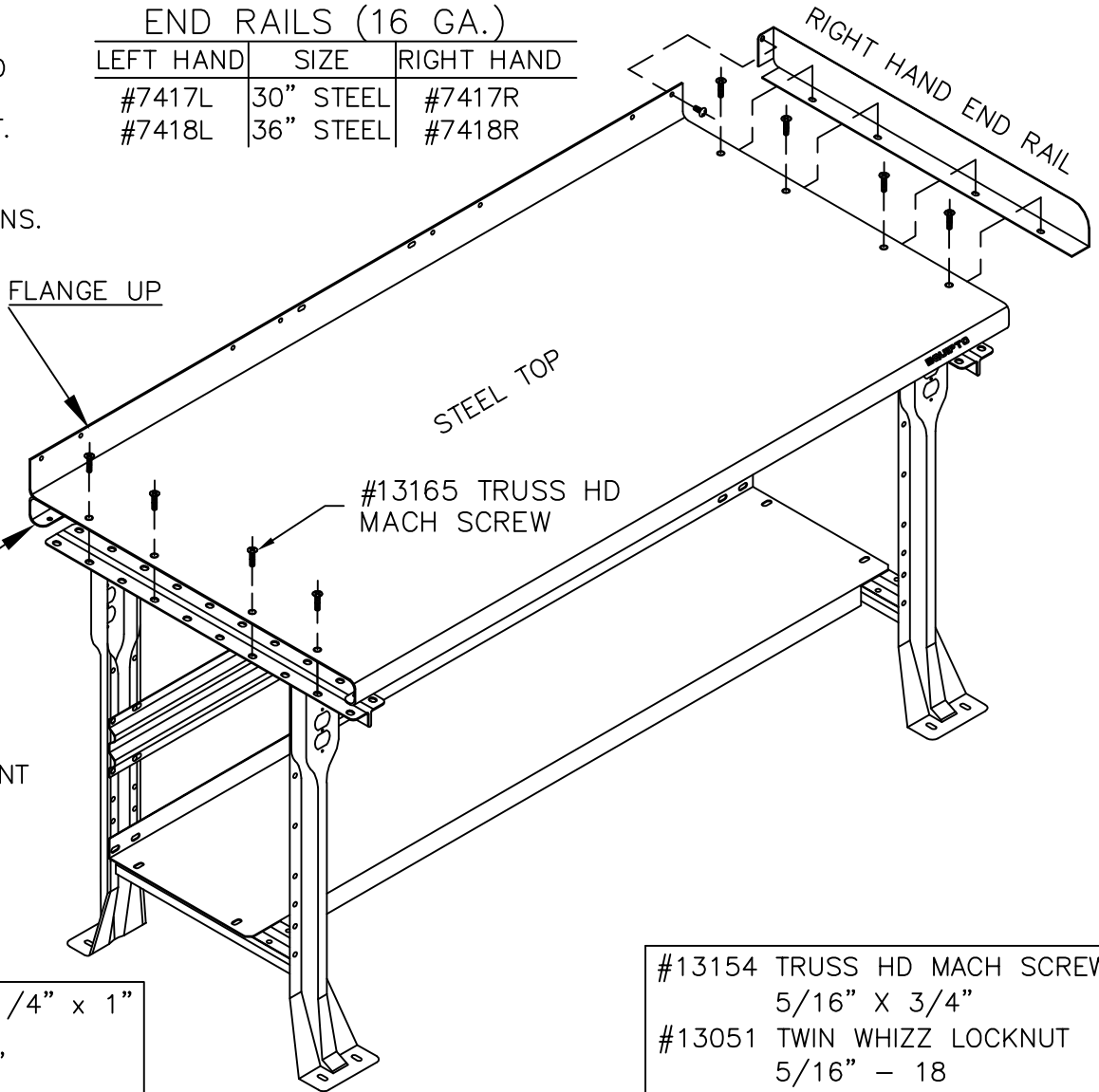

- #13165 FLAT HEAD BOLT 1/4" x 1"
- #13060 KEPS NUT 1/4"
- #13132 FLAT WASHER 1/4"

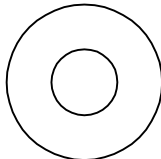
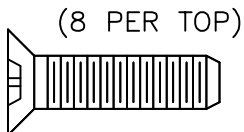

(8 PER TOP)

FULL SCALE

- #13154 TRUSS HD MACH SCREW 5/16" X 3/4"
- #13051 TWIN WHIZZ LOCKNUT 5/16" - 18
- (1 PER END RAIL)

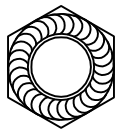
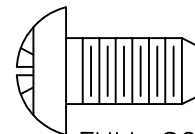

FULL SCALE

# Step

# 4

## FILLER INSTALLATION FOR 96" STEEL TOPS ONLY

FILLER (14 GA.)

FLANGE DOWN	SIZE	FLANGE UP
#7735	30"	#7737
#7736	36"	#7738

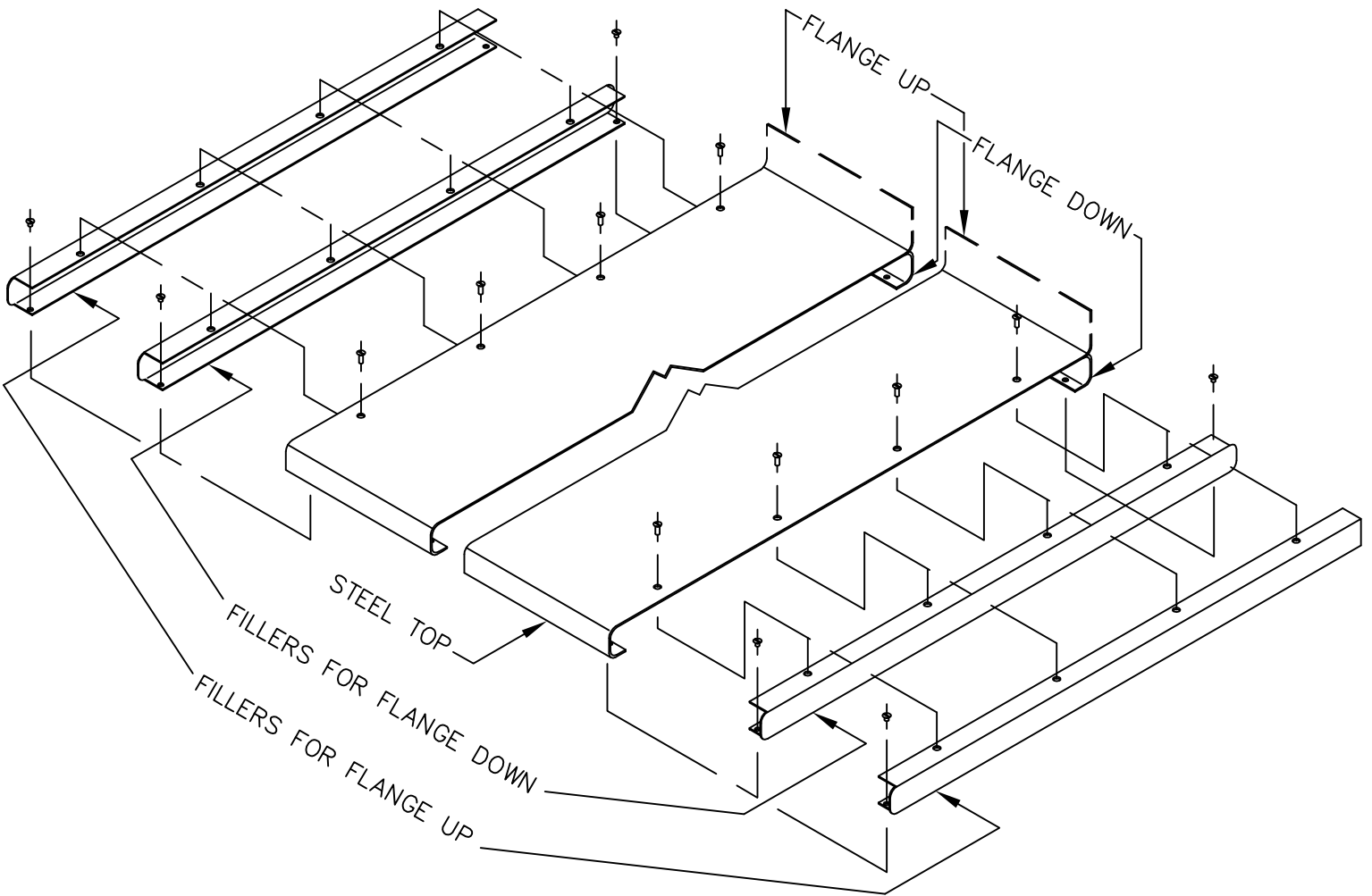

- #13165 FLAT HEAD BOLT 1/4" x 1"
- #13060 KEPS NUT 1/4"
- #13132 FLAT WASHER 1/4"

(8 PER TOP)

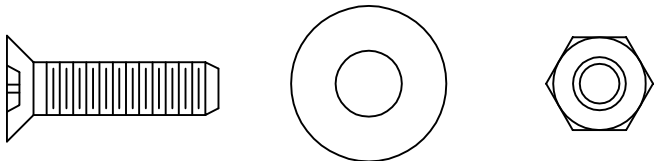

- #13162 TRUSS HD MACH SCREW 1/4" X 1/2"
- #13060 KEPS NUT 1/4"
- #13132 FLAT WASHER 1/4"

(2 PER FILLER FOR FLANGE DOWN)  
(1 PER FILLER FOR FLANGE UP)

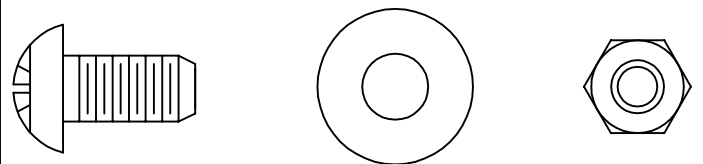

# 5

## WOOD TOP ASSEMBLY

### BONDED WOOD 1-3/4" THICK

### LAMINATED MAPLE 1-3/4" THICK

### CONDUCTIVE 1-1/4" THICK

- #12312 30" x 48"
- #12305 30" x 60"
- #12306 30" x 72"
- #12380 30" x 96"
- #12314 36" x 48"
- #12315 36" x 60"
- #12316 36" x 72"
- #12381 36" x 96"

- #12347 30" x 48"
- #12348 30" x 60"
- #12349 30" x 72"
- #12378 30" x 96"
- #12350 36" x 48"
- #12351 36" x 60"
- #12352 36" x 72"
- #12379 36" x 96"

- #12338 30" x 48"
- #12339 30" x 60"
- #12340 30" x 72"
- #12376 30" x 96"
- #12341 36" x 48"
- #12342 36" x 60"
- #12343 36" x 72"
- #12377 36" x 96"

### NOTE

OPTIONAL END AND BACK RAILS MUST BE ATTACHED AT THIS POINT.

### END RAILS (16 GA.)

LEFT HAND	SIZE	RIGHT HAND
#7420L	30" WOOD	#7420R
#7421L	36" WOOD	#7421R

### BACK RAILS

- #7404 - 48"
- #7405 - 60"
- #7406 - 72"
- #7411 - 96"

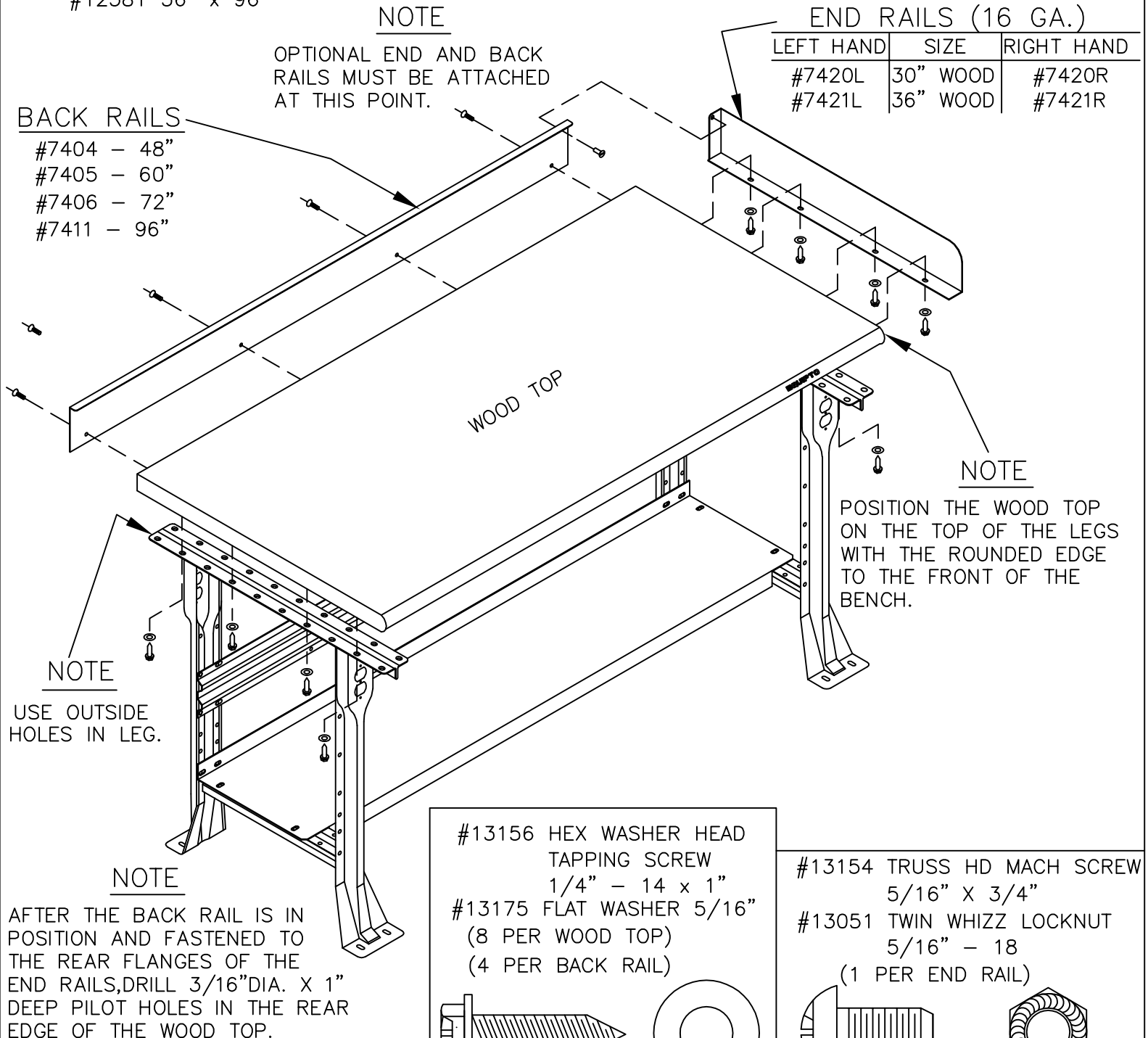

### NOTE

POSITION THE WOOD TOP ON THE TOP OF THE LEGS WITH THE ROUNDED EDGE TO THE FRONT OF THE BENCH.

### NOTE

USE OUTSIDE HOLES IN LEG.

### NOTE

AFTER THE BACK RAIL IS IN POSITION AND FASTENED TO THE REAR FLANGES OF THE END RAILS, DRILL 3/16" DIA. X 1" DEEP PILOT HOLES IN THE REAR EDGE OF THE WOOD TOP.

- #13156 HEX WASHER HEAD TAPPING SCREW 1/4" - 14 x 1"
- #13175 FLAT WASHER 5/16" (8 PER WOOD TOP) (4 PER BACK RAIL)

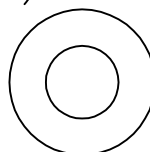
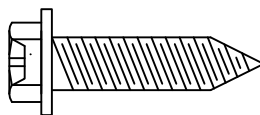

FULL SCALE

- #13154 TRUSS HD MACH SCREW 5/16" X 3/4"
- #13051 TWIN WHIZZ LOCKNUT 5/16" - 18 (1 PER END RAIL)

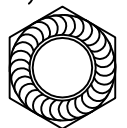
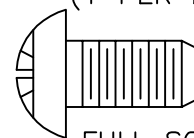

FULL SCALE

# Step

# 6

## CONTINUOUS BENCH ASSEMBLY

### NOTE

FASTEN BENCH TOP, BACK STRINGER AND BOTTOM SHELF OF ONE BENCH ASSEMBLY TO ONE HALF OF BENCH LEG AS SHOWN ABOVE. FASTEN ADDITIONAL BENCH PARTS TO THE OTHER HALF OF THE BENCH LEG.

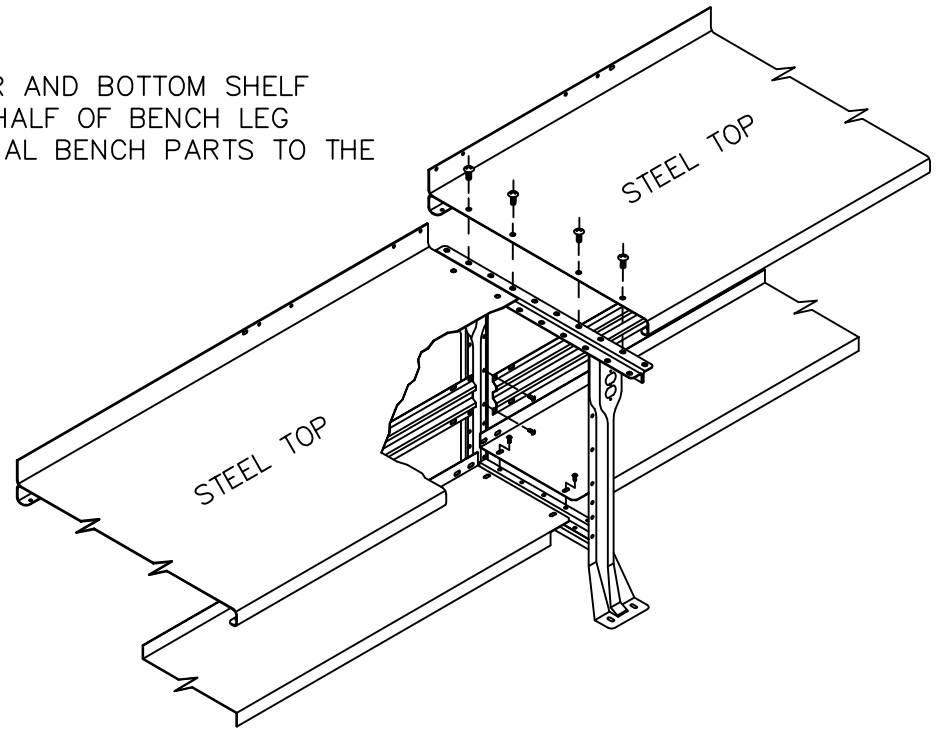

# Step

# 7

## MOBILE CASTER KIT

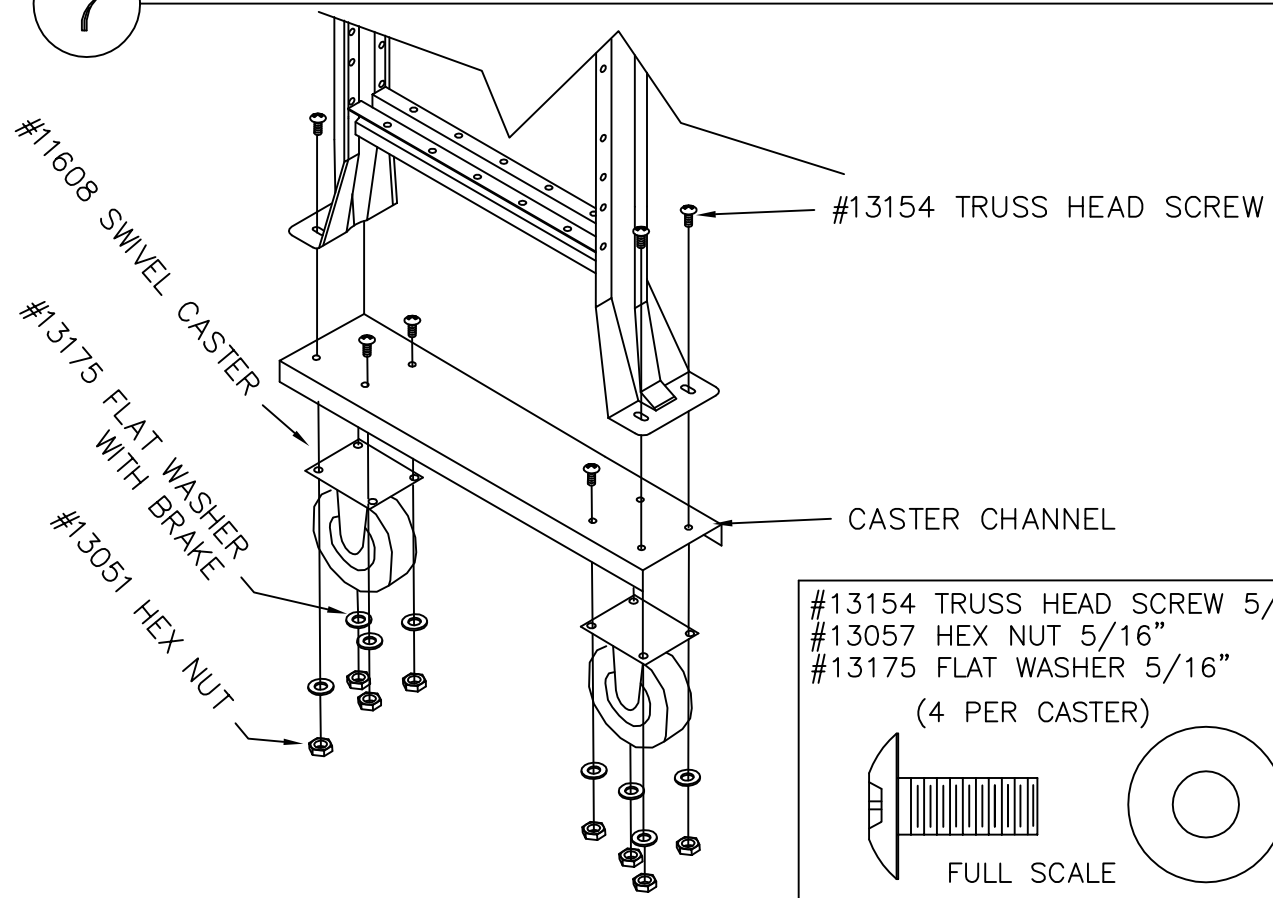

- #13154 TRUSS HEAD SCREW 5/16"-18 x 3/4"
- #13057 HEX NUT 5/16"
- #13175 FLAT WASHER 5/16"
- (4 PER CASTER)

